

City of El Monte

Planning Division

11333 Valley Boulevard

El Monte, CA 91731

P: (626) 258-8626

F: (626) 258-8628

<http://www.elmonteca.gov>



Parking Design Layout

Parking Stall Dimensions

- Standard Stall Size: 8'6" x 18'
- Handicap Stall Size: 17' x 20'

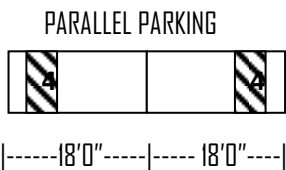
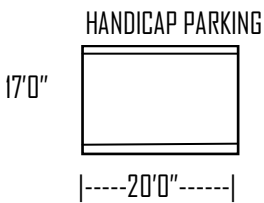

30° STANDARD PARKING

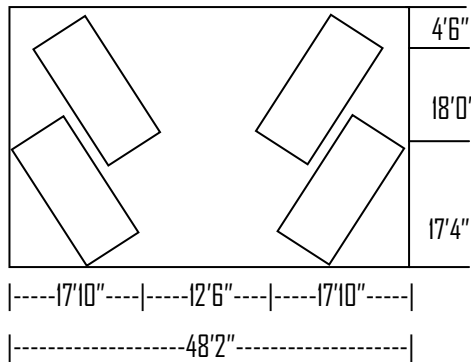

45° STANDARD PARKING

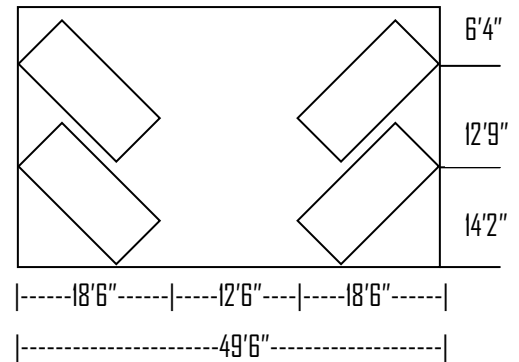

60° STANDARD PARKING

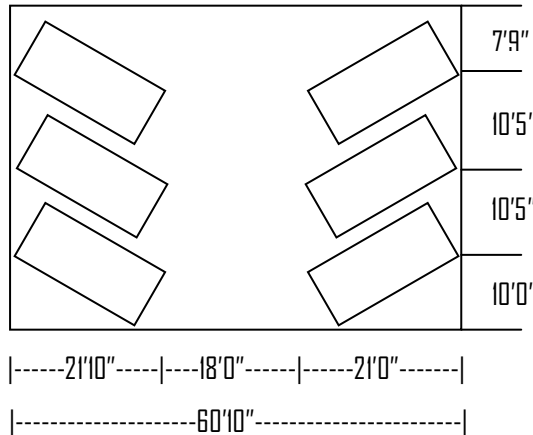

90° STANDARD PARKING

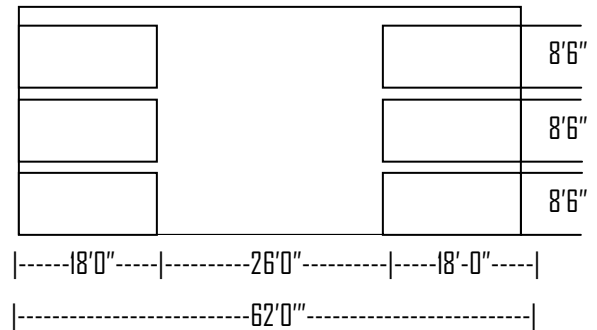

Notes

- All parking space dimensions are not clear area of required parking space (walls, footing, posts, are not to be included within the parking space area)
- All parking spaces shall be double striped per city specifications
- Bumper guards shall be provided to protect fences, walls, buildings, etc.
- Add 3 feet to end spaces abutting buildings, fences, or other obstructions

Please refer to Chapter 17.08 of the El Monte Municipal Code (available online) for further information.